

TRUE BLUE POWER® 
A division of Mid-Continent Instrument Co., Inc.

STC
APPROVED



KADEX
AERO SUPPLY 

Cessna Caravan®

208 / 208B Series

PT6A-114 / -114A / -140 / -42A Engines

Certified Lithium-ion Aircraft Battery Upgrade

Cessna Grand Caravan® EX



DISTRIBUTED BY
KADEX 

parts@kadexaero.com / Toll Free: +1-888-523-3988 / International: +1-705-742-9725 / www.kadexaero.com

Less Weight. Less Maintenance. **More Power. More Profit.**



TB44 Certified Lithium-ion Aircraft Battery

The TB44 Certified Lithium-ion Aircraft Battery features the most sophisticated lithium-ion chemistry available, providing Cessna Caravan® operators with an unmatched advantage of increased power, reduced weight, extended useful life, 2-year maintenance intervals, lower direct operating cost and higher profit potential.

The intelligent battery system's Nanophosphate® lithium-ion cells provide 3x the energy per kilogram and are rated up to 10,000 cycles, per cell. This results in a battery that is 29 - 32 pounds (36 - 38%) lighter than lead-acid and NiCad alternatives.

Safety is addressed on multiple levels, including chemistry, cell design, containment and the integration of electronic protections. The TB44 is a 'smart pack' engineered to protect against overcharge, over-discharge, over-current, short circuit, over-temperature and under-temperature.

Ideal for high utilization and rugged environments, the TB44 starts the aircraft's engine quickly and offers superior hot and cold weather performance.

A Supplemental Type Certificate (STC) approves installation of the TB44 on all Cessna Caravan® 208 and 208B series aircraft; engine types PT6A-114, -114A, -140, -42A.

Product Comparison – One Battery Per Aircraft

	Battery Technology	Voltage Output	Capacity (1C rate)	Weight	Maintenance	Useful Life
TB44	Lithium-ion	26.4 VDC	46 amp-hour	51.7 pounds	2 years	8 years (average)
Concorde RG-380E/40	Lead-acid	24 VDC	38 amp-hour	81 pounds	1 year (annual), 3 – 6 months (subsequent)	2 – 4 years
Saft 4078-19	Nickel-cadmium	24 VDC	43 amp-hour	84 pounds	200 – 400 hours	5 – 10 years

Caravan® Certified Lithium-ion Aircraft Battery Upgrade

Operational Value

- + Reduces empty weight and increases useful load
29 - 32 pounds less when compared to lead-acid and NiCad
- + Significantly reduced maintenance
Capacity check every two years
- + Superior high temperature and cold weather performance
-40°C to +70°C (-40°F to +158°F)
- + Reduces Caravan® fuel and maintenance costs
Up to \$2,000 per year per aircraft when compared to lead-acid batteries
- + Increased net present worth over 10 years
More than \$11,000 per aircraft when compared to lead-acid batteries
- + Environmentally friendly
No heavy metals and easy disposal
Reduced carbon emissions

Benefits

- + Significant weight savings
- + 8 year (average) useful life
- + Reduced direct operating costs
 - less fuel
 - less maintenance
 - less ground personnel
 - less infrastructure
- + Reduced turn times
- + Improved flight performance
- + Increased dispatch reliability
- + Increased engine & component life
- + Lower internal turbine start temperatures
- + Faster engine starts
- + Increased useful load
 - more cargo
 - more passengers
 - more baggage
 - more fuel
- + Increased customer satisfaction
- + No specialized test equipment required
- + Rapid recharge and high duty cycle
- + Built-in, automatic heater
- + Intelligent ARINC communication
- + Increased aircraft appreciation value
- + Higher turbo shaft rotation (N1) percentage



ACU installation has multiple approved placements on the instrument panel

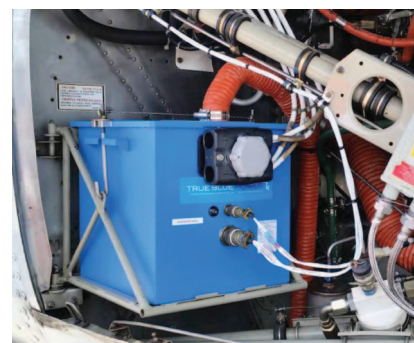

Installation of (1) TB44 Certified Lithium-ion Battery in Caravan® aircraft

“ After testing the True Blue Power lithium-ion battery and understanding **the amazing capabilities of this new technology**, I am convinced that the old lead acid or NiCad batteries will go the way of the rotary dial telephone. **It’s just so far advanced over current generation batteries.** With built-in sensors to monitor the health of the battery as well as a built-in heater, coupled with the weight savings and triple the lifespan, nothing can compete with this battery. **We are very excited to offer it to our Caravan® operators around the world.** ”

Jim Allmon
President & CEO, Blackhawk Modifications

PT6A-114
PT6A-114A
PT6A-140
PT6A-42A

This Supplemental Type Certificate approves installation of the True Blue Power® TB44 battery on all Cessna Caravan® 208 and 208B Series aircraft with these engine types.

Present Worth of Battery Related Costs per Aircraft (10 year)	Concorde RG-380E/40 Lead-acid Battery	True Blue Power® Certified Lithium-ion Battery
Initial Costs (PW_{ic})	– \$3,200	– \$13,500
Fuel Savings (PW_{fs})	\$0	\$8,388
Maintenance Costs (PW_{mc})	– \$2,458	– \$614
Replacement Costs (PW_{rc})	– \$5,570	– \$5,670
Aircraft Appreciation ($\Delta PW_{a/c}$)	\$0	\$11,408
Total Present Worth	– \$11,230	\$12
Total Present Worth Differential		\$11,242

TB44 Technical Specifications

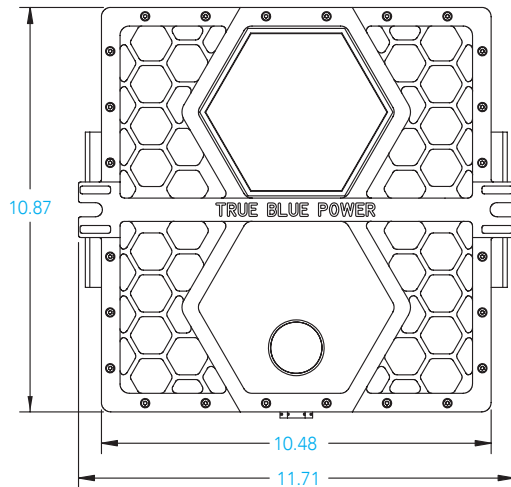

CAPACITY

46 amp-hour

CHARGE VOLTAGE

28 VDC nominal

OUTPUT VOLTAGE

26.4 VDC nominal

OPERATING TEMPERATURE

-40°C to +70°C (-40°F to +158°F)

WEIGHT

51.7 pounds

MAINTENANCE

Capacity check every two years

TECHNOLOGY

Nanophosphate[®] lithium-ion cell chemistry from A123 Systems, LLC

PROTECTION

Overcharge, over-discharge, over-current, short circuit, over- and under-temperature

MONITORING

ARINC 429 and analog data to the cockpit

CASE

Powder-coated steel, built to withstand 35 PSI pulse

CERTIFICATION

FAA TSO and EASA ETSO Certified
RTCA DO-311, DO-160G, DO-178B Qualified
UNDOT / IATA Certified

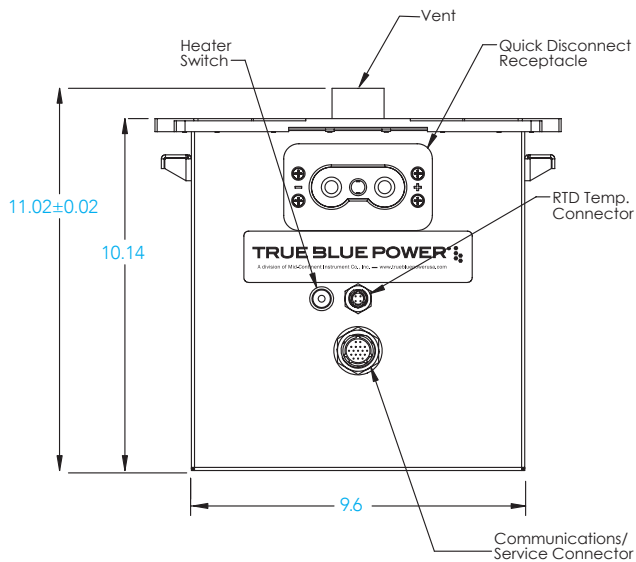

MD41-1844

Annunciation Control Unit

The MD41-1844 is a compact, self-contained Annunciation Control Unit (ACU). The fully integrated control unit provides annunciation for True Blue Power TB44 battery systems. It combines the necessary functions and annunciations required to interface with an approved system.

Highlighted features include long-life LEDs used for all lighting, internally backlit selection switch, daylight readable, deadfront inactive annunciations and automatic dimming. An external dimming adjustment is provided for balancing low-level light conditions.