

**ENGINE VIBRATION ISOLATORS  
TYPE 96301-01**

**Barry Controls™ Aerospace** designs and manufactures engine vibration isolation systems to meet the exacting standards of the aircraft industry. These systems are designed to reduce the magnitude of vibration transmitted from the propeller/powerplant to the airframe. Isolation provides: reduced pilot fatigue, passenger comfort, and maximum protection of the aircraft structure and systems from damaging vibration. To assure maximum protection and performance from the isolation system, replacement is recommended at each engine overhaul.

**Barry Controls™ Aerospace** has been granted Parts Manufacturer Approval (PMA) for engine vibration isolator type number 96301-01 used in the aircraft listed below. One engine vibration isolation system consists of four isolators, as noted below and on installation drawings. Each isolator consists of two molded assemblies, and an aluminum spacer.

**APPLICATIONS**

Aircraft Manufacturer	Aircraft Model	Serial Range	Engine	Isolators Per Aircraft
Cirrus	SR22	3712 and subsequent	Continental IO-500-N	(6) 96301-01
	SR22T	0001 and subsequent	Continental TSIO-550-K	(6) 96301-01

The above **Barry Controls™ Aerospace** vibration isolators are PMA approved for installation on the applications listed as direct replacements for the following part numbers:

Cirrus Part Number	Barry Controls Part Number
26757-001	96301-01

**Barry Controls™ Aerospace** vibration isolators are sold as assemblies. The illustrated parts breakdown and part number list is provided as reference only. For additional information, applications assistance, and technical support, please contact our customer service department.

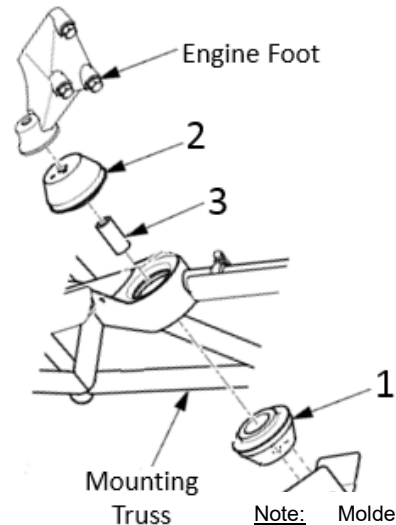
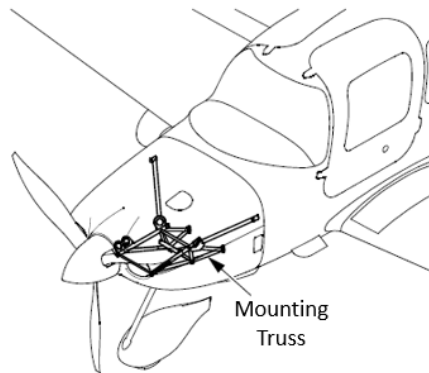
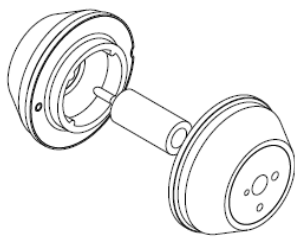

**Note:** Molded assemblies 00-14771-01 and 00-14772-01 are not interchangeable. Ensure correct placement of molded assemblies during installation.

Type 96301-01			
Item No.	Description	Part No.	Qty per Assy
1	Molded Assy	00-14771-01	1
2	Molded Assy	00-14772-01	1
3	Spacer	85-9384-01	1

Please refer to the aircraft's Illustrated Parts Catalog and Maintenance Manual for proper installation instructions.

**BARRY CONTROLS™**

