

BARRY CONTROLS

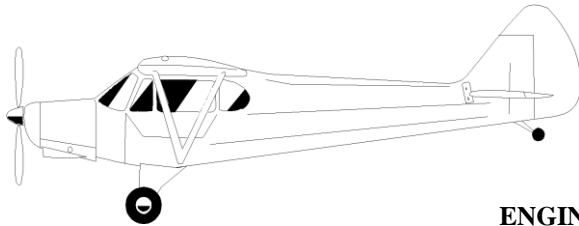

APPLICATION SHEET



FAA REPAIR STATION UT3R905L
JAA JAR 145.10
FAA-PMA PARTS MANUFACTURING APPROVED

ENGINE VIBRATION ISOLATORS TYPE 94016-02

Barry Controls™ Aerospace designs and manufactures engine vibration isolation systems to meet the exacting standards of the aircraft industry. These systems are designed to reduce the magnitude of vibration transmitted from the propeller/powerplant to the airframe. Isolation provides: reduced pilot fatigue, passenger comfort, and maximum protection of the aircraft structure and systems from the damaging effects of vibration. To maintain maximum performance and protection from the isolation system, replacement is recommended at each engine overhaul.



Barry Controls™ Aerospace has been granted Parts Manufacturers Approval (PMA) for vibration isolator type number 94016-02 for the aircraft listed below. Each engine vibration isolation system consists of four isolators. Each isolator consists of: two molded assemblies, a spacer, and an oversize OD washer. The spacer located between the two molded assemblies provides proper installation positioning and pre-compression.

APPLICATIONS

| AIRCRAFT MANUFACTURER | MODEL | POPULAR NAME | ENGINE(S) | ISOLATORS PER ENGINE | ISOLATORS PER AIRCRAFT |
|-----------------------|---|---|--|----------------------|------------------------|
| Extra | EA300 EA300/S EA300/L | Extra 300 Extra 300/S Extra 300/L Extra 300/LP Extra 300/LC Extra 300/LX | LYC AEIO-540-L1B5, -L1B5D LYC AEIO-540-L1B5, -L1B5D LYC AEIO-540-L1B5, -L1B5D, -580-B1A | 4 | 4 |
| | EA300/LC | | LYC AEIO-580-B1A | | |
| Maule | M-5-235-C | Lunar Rocket | LYC O-540-B4B5 LYC O-540-J1A5D LYC O-540-J3A5 LYC IO-540-W1A5 LYC IO-540-W1A5D | 4 | 4 |
| | M-6-235 | Super Rocket | LYC O-540-B4B5 LYC O-540-J1A5D LYC O-540-J3A5 LYC IO-540-W1A5 LYC IO-540-W1A5D | | |
| | M-7-235 M-7-235A M-7-235B M-7-235C M-7-260 M-7-260C M-8-235 MT-7-235 MT-7-260 MX-7-235 | | | | |
| Zlin | Z-242L | | LYC AEIO-360-A1B6 | 4 | 4 |

Barry Controls™ Aerospace vibration isolators are sold as assemblies. The illustrated parts breakdown and part number list is provided as reference only. For additional information, applications assistance, and technical support, please contact our customer service department.

APPLICATION SHEET

BARRY CONTROLS

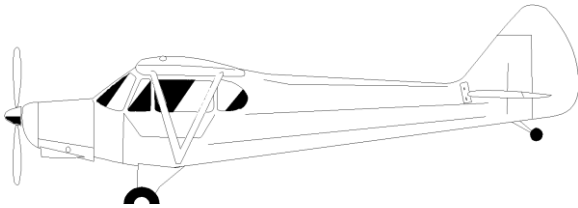

FAA REPAIR STATION UT3R905L
 JAA JAR 145.10
 FAA-PMA PARTS MANUFACTURING APPROVED

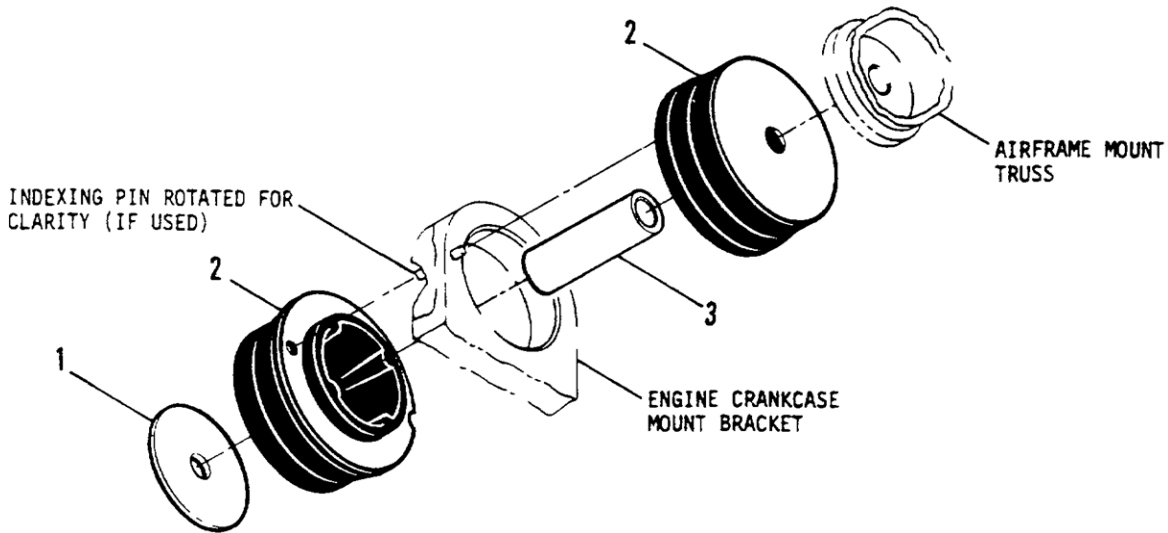
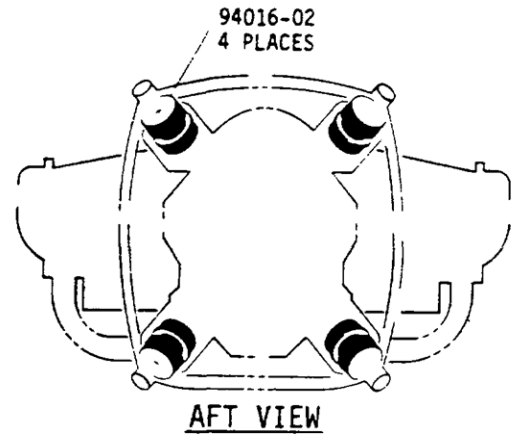
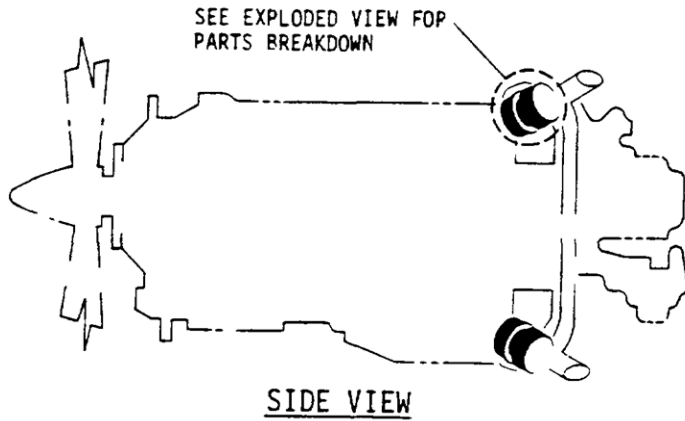

| ITEM | DESCRIPTION | PART NUMBER | UNITS PER ASSEMBLY |
|------|-----------------|-------------|--------------------|
| 1 | WASHER | 98-9074-11 | 1 |
| 2 | MOLDED ASSEMBLY | 00-11901-12 | 2 |
| 3 | SPACER | 85-9217-05 | 1 |